

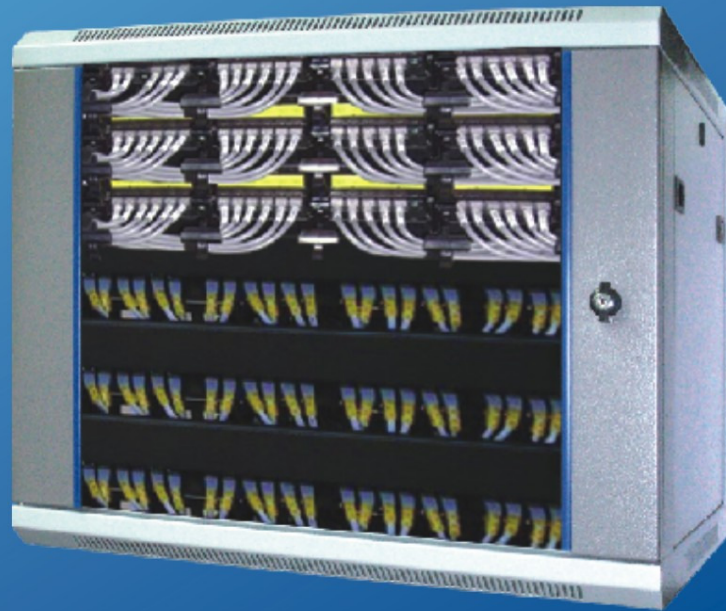

WALL MOUNT RACK



providing you with excellent professional
networking opportunities



CW Class - Wall Mount Enclosure

CW wall-mounted enclosures are cutting-edge products in enclosure technology. The distinct concepts have one crucial factor in common - convenient access to all installed equipment for assembly and servicing purposes.

- Easy and uninhibited access to all mounting points, thanks to the cover system
- Brush strip and combination rail for cable clamping
- Security locks
- Integral ventilation concept
- Time-saving, cost-cutting assembly
- Swing Frame (Option)
- Fan Unit (Option)



Ordering Information

Effective Height (U)	Overall Dimension	Width / Depth (mm)	Order Code (Two Tone Grey)	Order Code (Anthracite Black)
18U	950mm / 37"	600 x 500	CW 18.5 G	CW 18.5
		600 x 600	CW 18.6 G	CW 18.6
15U	800mm / 31.5"	600 x 500	CW 15.5 G	CW 15.5
		600 x 600	CW 15.6 G	CW 15.6
12U	650mm / 25.5"	600 x 500	CW 12.5 G	CW 12.5
		600 x 600	CW 12.6 G	CW 12.6
9U	500mm / 19.5"	600 x 500	CW 9.5 G	CW 9.5
		600 x 600	CW 9.6 G	CW 9.6
6U	350mm / 13.5"	600 x 500	CW 6.5 G	CW 6.5
		600 x 600	CW 6.6 G	CW 6.6

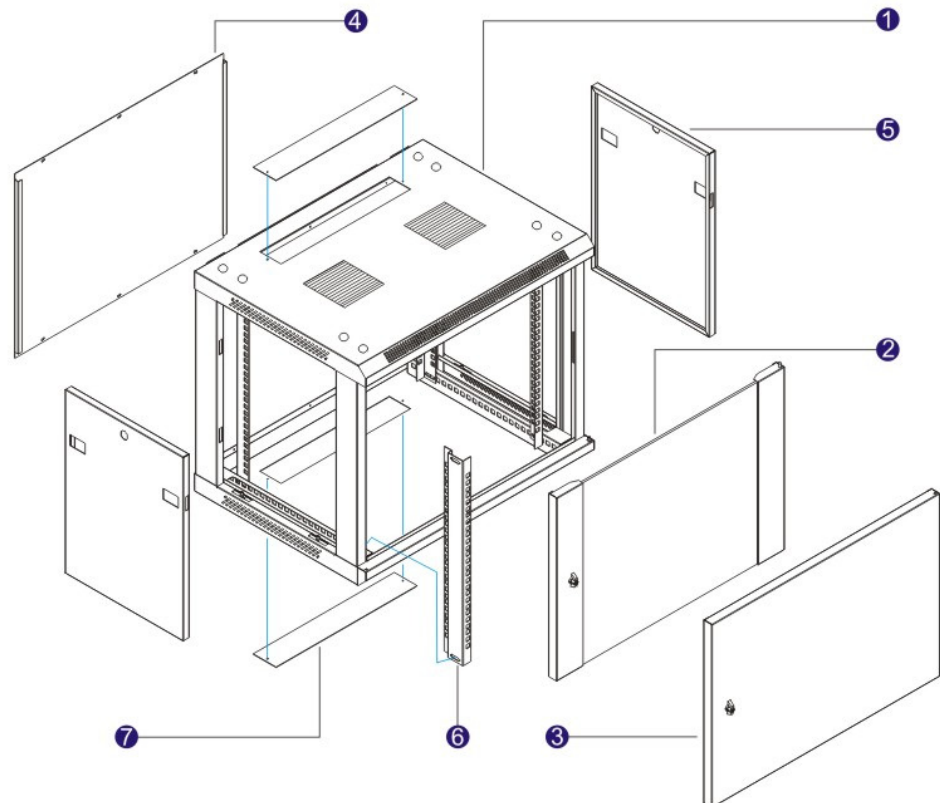

STRUCTURE

1. Main Frame
2. Glass Front Door
3. Steel Front Door
4. Steel Rear Panel
5. Quick Release Side Panel w/ Clip Lock
6. Adjustable 19" Panel Mounting Angle
7. Top and Base Cover